

1.5 kW

Swept Area 4.5mq

Rated Power (kW)
Rated Wind Speed (m/s)
Maximum Power (kWp @ 14 m/s)
Rotor Diameter (m)
Rotor Height (m)
Cut-in Wind Speed (m/s)
Cut-out Wind Speed (m/s)

1.0
12
1.5
3
1.5
3
Self limiting

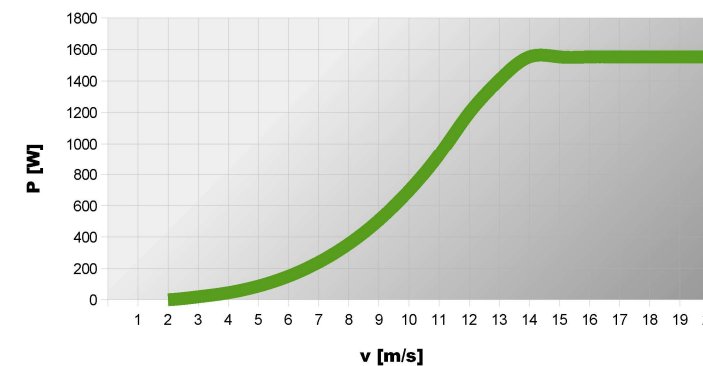
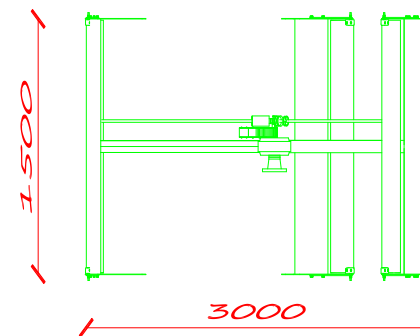

Annual Energy 3387 kWh - with average wind speed 7m/s

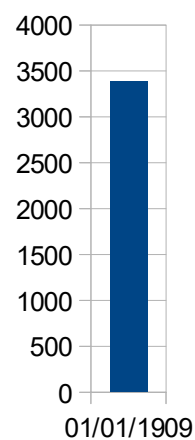
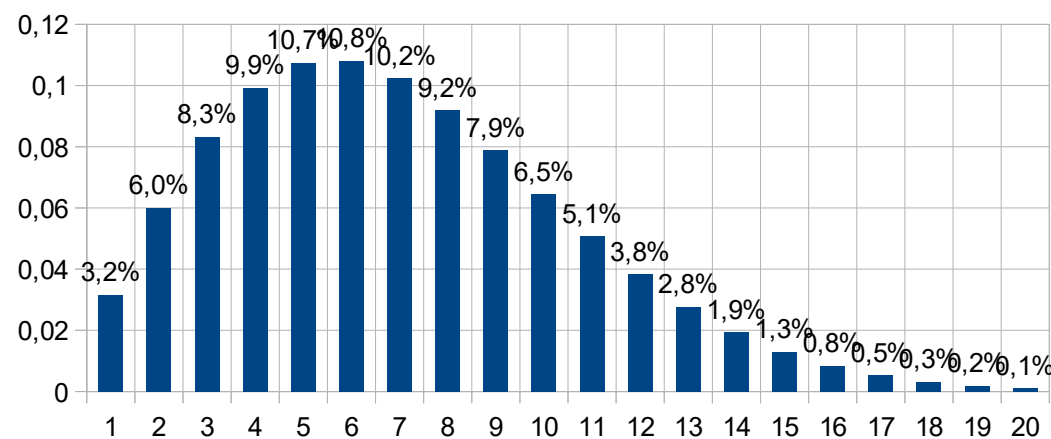

Annual Energy 1426 kWh - with average wind speed 5m/s

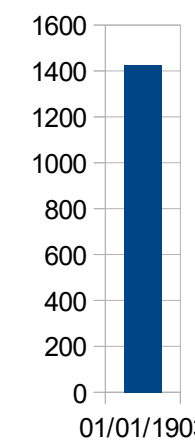
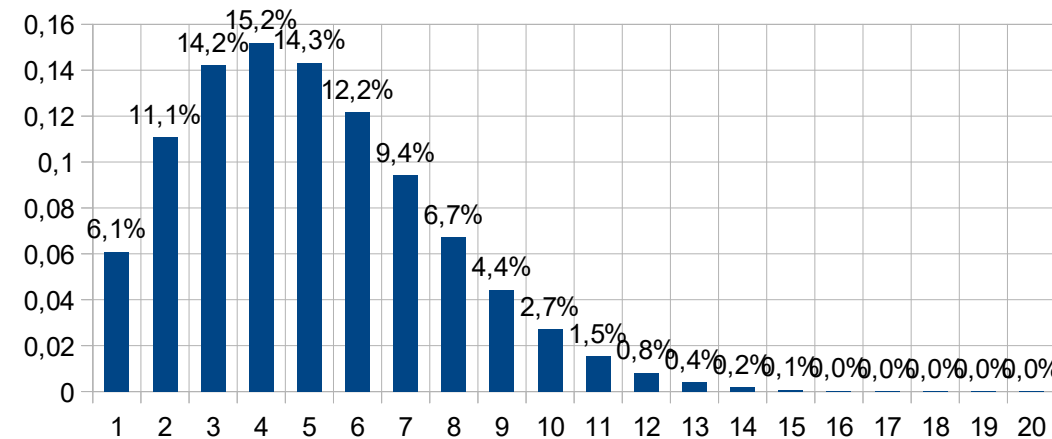

Annual Energy 2347 kWh - with average wind speed 6m/s

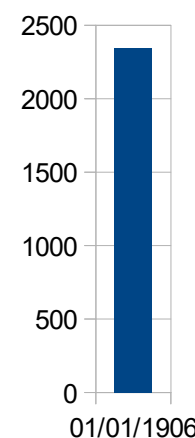
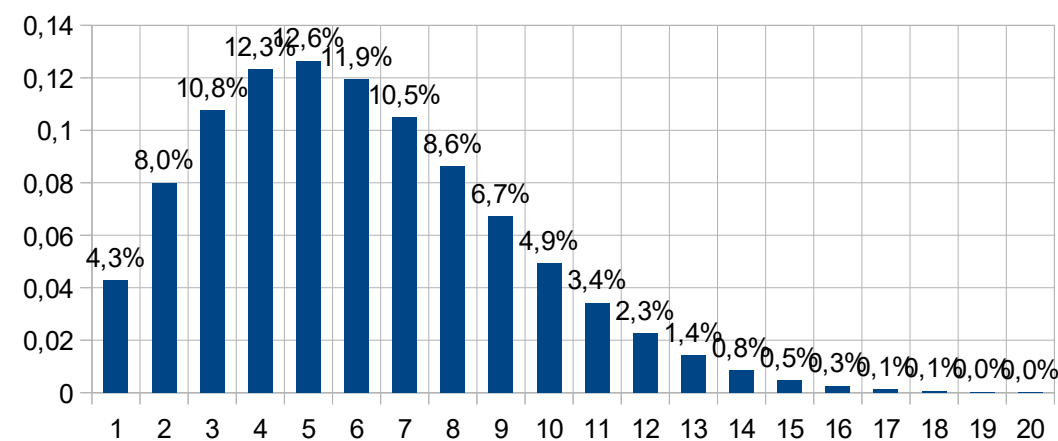

Annual Energy 736 kWh - with average wind speed 4m/s

